

ENGINE POWERED TOWING TRACTOR

# 2TG/2TD

2.0 and 2.5 ton  
Series



The model shown is equipped with optional equipment.

## COMPLETE PROFESSIONAL

Advanced TOYOTA technology introduces 2.0 and 2.5 ton series towing tractors.

Designed to meet demanding professional needs, the fast traveling speed and small turning radius bring outstanding maneuverability to any worksite.

## Complete Potential

Powerful 2Z Diesel Engine (42-2TD20,25 models)



Toyota offers its powerful 3.5 liter 2Z diesel engine on 42-2TD20,25 models. It makes heavy work fast and effortless.

<b>Rated Power</b> <b>48.5 kW</b> /2,200rpm	<b>Piston Displacement</b> <b>3,469 cc</b>
<b>Rated Torque</b> <b>216 N-m</b> /1,600rpm	<b>Travel Speed</b> <b>30 km/h</b> (No Load) <b>23 km/h</b> (with 16t Load)

Small Turning Radius

Small turning radius offers comfortable maneuvering even in narrow space.

**Turning Radius (Outside)**

[ (02-)2TG20,25 (02-)2TD20,25 ] <b>3,050 mm</b>
[42-2TD20,25] <b>3,200 mm</b>

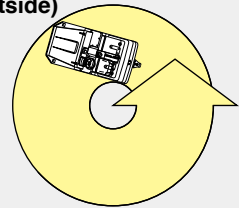

## Complete Operability

Operator's Compartment

Steering wheel with power steering system and adjustable steering column provide excellent maneuverability. Meters and gauge in an integrated layout makes it easy to check the vehicle status.



Drawbar Lever & Pin

The operator has a clear view of the drawbar pin from the seat, and can easily operate the drawbar lever. A hydraulic drawbar lever is available as an option.



Seat

This seat supports to reduce fatigue during long hours operation. A suspension seat is optionally available to help soften the ride even more.



**NEW** Retractable Seat Belt **OPT**

The seat belt with ELR (Emergency Locking Retractor) is available. ELR allows the belt to freely extend and retract with operator movement, yet locks the belt during a sudden stop or upon impact.



Low and Non-slip Floor

The low and non-slip floor supports frequent getting on and off.



Automatic Transmission

(02-, 42- Model)

The automatic transmission automatically shifts from L to 2 to D, it provides smooth operation.



Steel Cabin **OPT**

The steel cabin helps to boost both comfort and safety even in extremely cold or rainy climate.



# 2TG/2TD

ENGINE POWERED TOWING TRACTOR

2.0 and 2.5 ton  
Series

## Main Specifications

Model			2TG20 2TD20	2TG25 2TD25
Engine Model			4Y 1DZ-II,(2Z)	4Y 1DZ-II,(2Z)
Maximum Drawbar Pull	kg		2,000	2,500
	N		19,500	24,500
Gradeability*	% (tan θ)		46	46
Overall Width	A	mm	1,445	1,445
Turning Radius (Outside)	B	mm	3,050 (3,200)	3,050 (3,200)
Overall Height	C	mm	1,390	1,390
Overall Length	D	mm	3,020 (3,130)	3,020 (3,130)

NOTE: \*At forward 1st speed. ( ) for 2Z engine model.

## Engine Specifications

Model		TOYOTA 4Y Gasoline	TOYOTA 1DZ-II Diesel	TOYOTA 2Z Diesel
Piston Displacement	cc	2,237	2,486	3,469
Rated Power/r.p.m	kW	39.7/2,400	40.5/2,400	48.5/2,200
	JIS ps	54/2,400	55/2,400	66/2,200
Rated Torque/r.p.m	N-m	162/1,800	167/1,600	216/1,600
	JIS kg-m	16.5/1,800	17/1,600	22/1,600

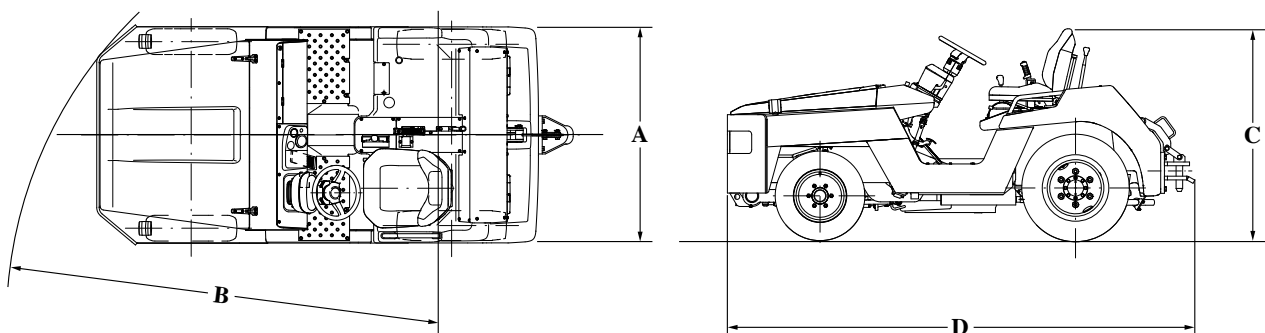

The data in this leaflet is determined based on our standard testing condition.  
The performance may vary depending on the actual specification and condition of the vehicle as well as the condition of the operating area.  
Availability and specifications depend on market and are subject to change without notice.  
Due to photography and printing, color of actual vehicle may vary from this leaflet. Some photos have been computer-enhanced.  
Please consult your Toyota representative for details.  
Photographs may include optional equipment.

All rights reserved by Toyota Industries Corporation.



TOYOTA MATERIAL HANDLING INTERNATIONAL

LF.2TG/2TD20.25(TOWING SERIES)/E-2001/©/Printed in Japan/No.710480E0/500