

Pedestrian lowlifter truck 1.4 - 1.6 ton

BT levio

W-series

LWE140

LWE160



Pedestrian lowlifter truck

Specification for lowlifter trucks					LWE140	LWE160
Identification	1.1	Manufacturer			BT	BT
	1.2	Model			LWE140	LWE160
	1.3	Drive			Electric	Electric
	1.4	Operator type			Pedestrian	Pedestrian
	1.5	Load capacity/rated load	Q	kg	1400	1600
	1.6	Load centre	c	mm	600	600
	1.8	Load distance, centre of support arm wheel to face of forks (forks raised/lowered)	x	mm	928/983 *)	928/983 *)
	1.9	Wheelbase (forks raised/lowered)	y	mm	1260/1315	1317/1372
	Weight	2.1	Service weight including battery		kg	458
2.2		Axle load, with load, drive/castor/fork wheel		kg	590/150/1115	695/150/1275
2.3		Axle load, without load, drive/castor/fork wheel		kg	200/150/105	255/150/115
Wheels	3.1	Drive/castor/fork wheel			Topthane/Topthane/PUR *)	Topthane/Topthane/PUR *)
	3.2	Wheel size, front		mm	Ø230x70	Ø230x70
	3.3	Wheel size, rear		mm	Ø85x100	Ø85x100
	3.4	Additional wheels (dimensions)		mm	Ø125x50	Ø125x50
	3.5	Wheels, number front/rear (x = driven wheels)			1x+2/2	1x+2/2
	3.6	Track width, front	b ₁₀	mm	430	430
	3.7	Track width, rear	b ₁₁	mm	394	394
Dimensions	4.4	Lift	h ₃	mm	120	120
		Lift height	h ₂₃	mm	205	205
	4.9	Height of tiller in drive position, min./max.	h ₁₄	mm	865/1235	865/1235
	4.15	Height, fork lowered	h ₁₃	mm	85	85
	4.19	Overall length	l ₁	mm	1631	1688
	4.20	Length to face of forks	l ₂	mm	481	538
	4.21	Overall width	b ₁	mm	726	726
	4.22	Fork dimensions	s/e/l	mm	76/156/1150 *)	76/156/1150 *)
	4.25	Width over forks	b ₅	mm	550 *)	550 *)
	4.32	Ground clearance, centre of wheelbase	m ₂	mm	21	21
	4.33	Aisle width for pallets 1000x1200 crossways	A _{st}	mm	1842	1899
	4.34	Aisle width for pallets 800x1200 lengthways	A _{st}	mm	1892	1949
	4.35	Turning radius	W _a	mm	1420	1477
Performance data	5.1	Travel speed, with/without load		km/h	6/6	6/6
	5.2	Lift speed, with/without load		m/s	0,04/0,05	0,04/0,05
	5.3	Lowering speed, with/without load		m/s	0,09/0,08	0,09/0,08
	5.8	Max. gradeability, with/without load		%	8/18 ¹⁾	8/18 ¹⁾
	5.10	Service brake			Electromagnetic	Electromagnetic
Electric motor	6.1	Drive motor rating S2 60 min		kW	1,0	1,0
	6.2	Lift motor rating at S3 15%		kW	1,0 ²⁾	1,0 ²⁾
	6.4	Battery voltage/nominal capacity K _s		V/Ah	24/150	24/225 *)
	6.5	Battery weight		kg	158	214 *)
	6.6	Energy consumption acc. to VDI cycle		kWh/h	0,25	—
	8.1	Type of drive control			BT Powerdrive	BT Powerdrive

¹⁾ Measured according to company standard

²⁾ S3 10%

*) Further alternatives are available and will produce other values.

Data is based on standard configurations: Small battery compartment (LWE140) and Medium battery compartment (LWE160).

Truck performance and dimensions are nominal and subject to tolerances.

Toyota Material Handling Manufacturing Sweden AB products and specifications are subject to change without notice.

Battery dependent dimensions

BT levio

Dimensions		Battery Compartment		LWE140	LWE160	
				Small	Small	Medium
1.9	Wheelbase	y	mm	1260	1260	1317
4.19	Overall length	l_1	mm	1631	1631	1688
4.20	Length to face of forks	l_2	mm	481	481	538
4.33	Aisle width for pallets 1000x1200 crossways	A_{st}	mm	1842	1842	1899
4.34	Aisle width for pallets 800x1200 lengthways	A_{st}	mm	1892	1892	1949
4.35	Turning radius	W_a	mm	1420	1420	1477
6.4	Battery voltage, nominal capacity K_5		V/Ah	24/150	24/150	24/225
6.5	Battery weight, min.—max.		kg	120—165	120—165	180—220

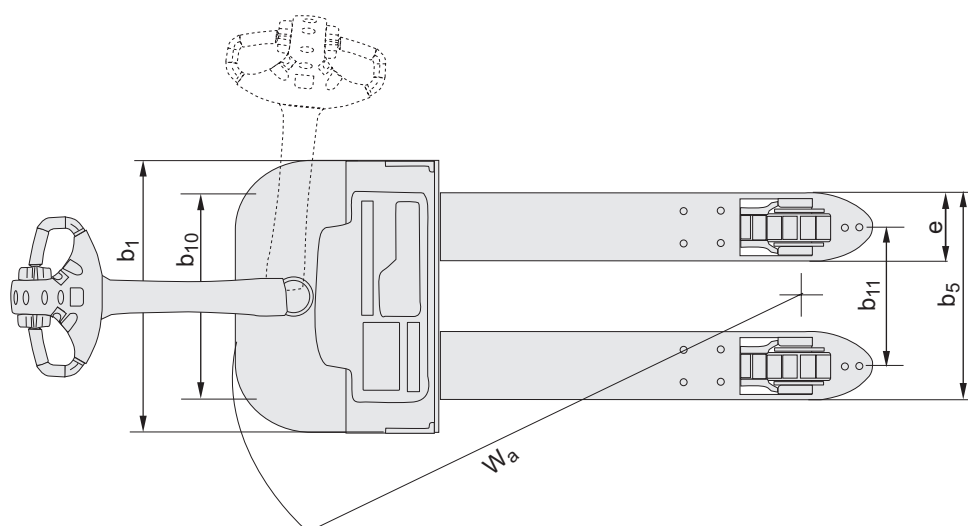
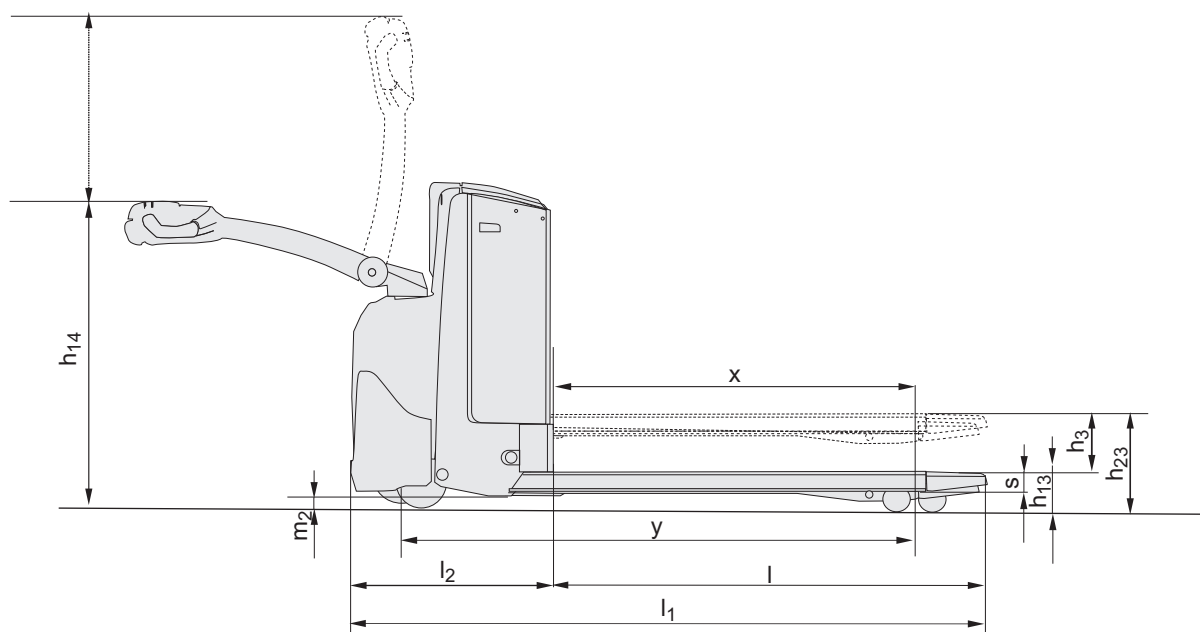

Truck features:

- BT Powerdrive System
- BT Castorlink System
- Click-2-creep
- Fingertip controls
- Temporary speed reduction - turtle button (option)
- Electronic braking system
- Electronic speed control
- Operator safety
- Storage compartments
- Automatic switch-off
- Programmable performance
- Easy access for maintenance
- Built in charger (option)
- Toyota I_site: truck fleet management system (option)
- Hydraulic oil for low temperatures (option)

