

Order picking truck 1.2 ton

BT optio
H-series
OME120HW



Order picking truck

Truck specifications					OME120HW , Duplex mast	OME120HW , Triplex mast
Identification	1.1	Manufacturer			Toyota	Toyota
	1.2	Model			OME120HW , Duplex mast	OME120HW , Triplex mast
	1.3	Drive			Electric	Electric
	1.4	Operator type			Stand on	Stand on
	1.5	Load capacity/rated load	Q	kg	1080	1080
	1.6	Load centre	c	mm	600	600
	1.8	Load distance, centre of load axle to fork face	x	mm	193	218
	1.9	Wheelbase	y	mm	1477	1503
	Weight	2.1	Service weight including battery		kg	3023
2.2		Axle load, with load, drive/fork wheel		kg	1097/3030	1518/3375
2.3		Axle load, without load, drive/fork wheel		kg	1696/1327	2126/1665
Wheels	3.1	Drive/fork wheel			Vulkollan	Vulkollan
	3.2	Wheel size, front		mm	Ø 230 x 110	Ø 230 x 110
	3.3	Wheel size, rear		mm	Ø 350 x 140	Ø 350 x 140
	3.5	Wheels, number front/rear (x = driven wheels)			2/1 (*)	2/1 (*)
	3.6	Track width, front	b ₁₀	mm	910	1110
	Dimensions	4.2	Height, mast lowered	h ₁	mm	3152
4.4		Lift movement	h ₃	mm	4689	6987
		Lift height	h ₂₃	mm	4768	7067
4.5		Height, mast extended	h ₄	mm	7100	9400
4.7		Height of overhead guard (cab)	h ₆	mm	2402	2402
4.8		Stand height	h ₇	mm	305	305
4.11		Initial lift movement	h ₉	mm	—	—
4.14		Stand height, elevated	h ₁₂	mm	5000	7300
4.14.1		Picking height (h ₁₂ + 1600 mm)	h ₂₈	mm	6600	8900
4.19		Overall length	l ₁	mm	3133	3209
4.20		Length to face of forks	l ₂	mm	1882	1959
4.21		Overall width ¹⁾	b ₁ /b ₂	mm	1050/1010	1250/1010
4.22		Fork dimensions	s/e/l	mm	62/115/1250	62/115/1250
4.25		Width over forks	b ₅	mm	560	560
4.31		Ground clearance, with load, below mast	m ₁	mm	52	52
4.32		Ground clearance, centre of wheelbase	m ₂	mm	52	52
4.33		Aisle width for pallets 1000x1200 crossways	A _{st}	mm	1610	1710
4.34		Aisle width for pallets 800x1200 lengthways	A _{st}	mm	1210	1510
4.35		Turning radius	W _a	mm	1689	1741
4.41		Transfer aisle width, 800x1200 lengthways	Au	mm	3265	3341
4.44	Clear width driver compartment entrance	l ₂₄	mm	555	555	
Performance data	5.1	Travel speed, with/without load		km/h	12,0/12,0	12,0/12,0
	5.2	Lift speed, with/without load		m/s	0,35/0,40	0,35/0,40
	5.3	Lowering speed, with/without load		m/s	0,45/0,45	0,45/0,45
	5.9	Acceleration time (0-10 meters), with/without load		s	6,0/5,5	6,0/5,5
	5.10	Service brake			Electric	Electric
Electric motor	6.1	Drive motor rating S2 60 min		kW	7,5	7,5
	6.2	Lift motor rating S3 15%		kW	11	11
	6.4	Battery voltage, nominal capacity K ₅		V/Ah	48/465	48/620
	6.5	Battery weight		kg	725-810	925-1035
	6.6	Energy consumption acc to VDI cycle		kWh/h	3,09	3,33
	Other	8.1	Type of drive control			Variable AC
8.4		Sound level at the driver's ear according to EN 12 053		dB(A)	60	60
8.6		Steering			Electric	Electric

1) b₁ = chassis width, b₂ = cab width

All data are based on table configuration. Other configurations may give other values.

Truck performance and dimensions are nominal and subject to tolerances.

Toyota Material Handling Manufacturing Sweden AB products and specifications are subject to change without notice.

Mast dimensions

BT optio

Chassis width, b_1 (mm)		Battery		Duplex Telescopic										Triplex Telescopic							
OME120HW/OME120HWC	1050	465 Ah		X	X	X	X	—	—	—	—	—	—	X	X	—	—	—	—		
	1250	465/620Ah		—	—	—	—	X/X	X/X	X/X	X/X	X/X	—/X	—/X	X/X	X/X	X/X	X/X	—/X	—/X	
	Platform height		h_{12}	mm	3550	3950	4500	5000	5500	6000	6500	7000	7500	8000	8500	5500	6100	7300	8200	9500	10500
	Height, mast lowered		h_1	mm	2427	2627	2902	3152	3402	3652	3902	4152	4402	4652	4902	2657	2857	3367	3867	4300	4933
	Lift movement		h_3	mm	3239	3639	4189	4689	5189	5689	6189	6689	7189	7689	8189	5187	5787	6987	7887	9187	10187
	Height, mast extended		h_4	mm	5650	6050	6600	7100	7600	8100	8600	9100	9600	10100	10600	7600	8200	9400	10300	11600	12600
	Picking height		h_{28}	mm	5150	5550	6100	6600	7100	7600	8100	8600	9100	9600	10100	7100	7700	8900	9800	11100	12100
	Total lift height		h_{23}	mm	3318	3718	4268	4768	5268	5768	6268	6768	7268	7768	8268	5267	5867	7067	7967	9266	10266

X = Available combination

— = Non available combination

Working aisle widths

OME120HW/OME120HWC	Standard values			Rail guided trucks				Wire guided trucks			
				EUR pallet		CHEP pallet		EUR pallet		CHEP pallet	
	Handling type			LS	SS	LS	SS	LS	SS	LS	SS
Pallet length			mm	800	1200	1000	1200	800	1200	1000	1200
Pallet width			mm	1200	800	1200	1000	1200	800	1200	1000
Load frame inner dim. ($b_{21} \times l_{21}$)			mm	1290 x 820	890 x 1220	1290 x 1020	1090 x 1220	1290 x 820	890 x 1220	1290 x 1020	1090 x 1220
Load frame outer dim. ($b_{22} \times l_{22}$)			mm	1410 x 900	1010 x 1300	1410 x 1100	1210 x 1300	1410 x 900	1010 x 1300	1410 x 1100	1210 x 1300
Chassis width			b_1 mm	1050/1250	1050/1250	1050/1250	1050/1250	1050/1250	1050/1250	1050/1250	1050/1250
Distance between pallets in aisle			Ast mm	1610/1610	1210/1410	1610/1610	1410/1410	1710/1710	1310/1510	1710/1710	1510/1510
Transfer aisle, VDI Theoretical			Ast ₃ mm	2990/3063	3265/3341	3162/3236	3300/3375	2990/3063	3265/3341	3162/3236	3300/3375
Transfer aisle, Practical ¹⁾			Ast ₃ mm	3490/3563	3765/3841	3662/3736	3800/3875	3990/4063	4265/4341	4162/4236	4300/4375

LS = Long side pallet handling

SS = Short side pallet handling

1) Transfer aisle requirement including recommended operation safety space

Chassis width, 1050 mm equipped with Duplex mast

Chassis width, 1250 mm equipped with Triplex mast

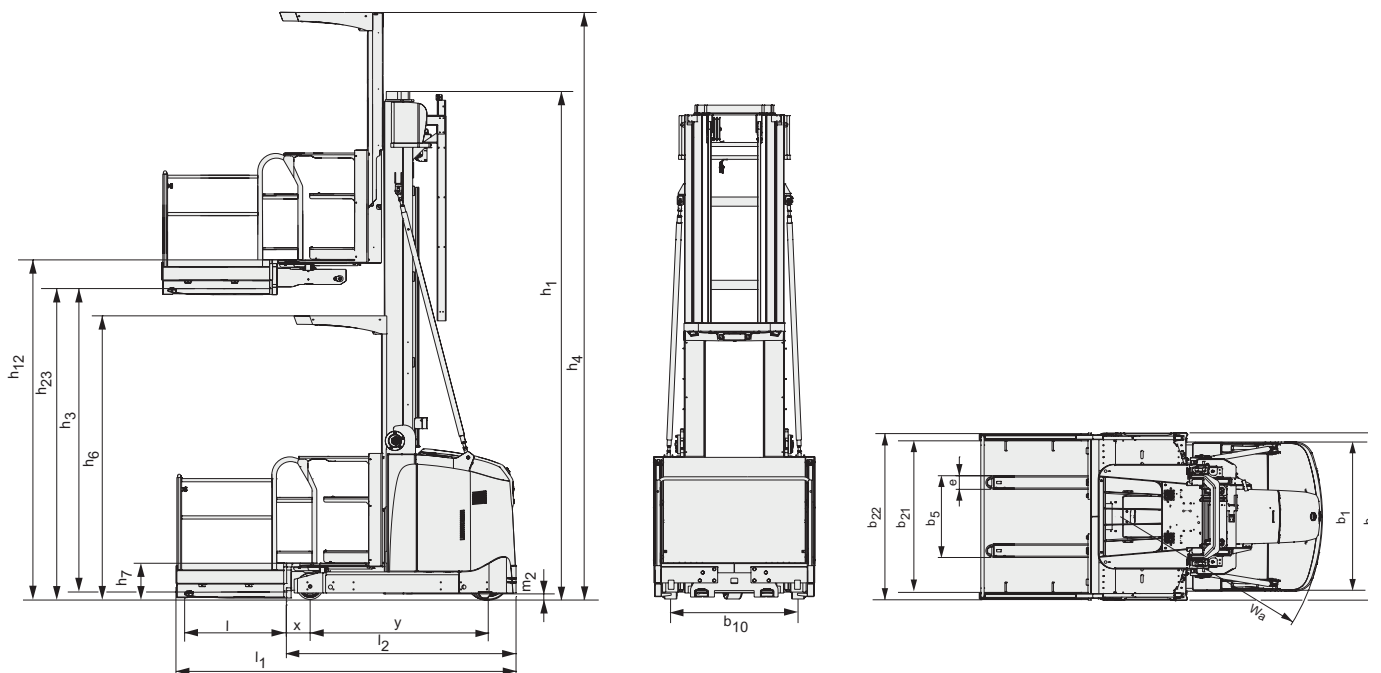

Truck features:

- High picking heights
- Powerful drive & lift motor (AC)
- Regenerative power when braking and lowering the cab
- Spacious cab with storage compartments
- Height adjustable control panel with intuitive controls
- Information display showing all vital information
- E-bars for mounting of peripheral equipment
- Several load frames available
- Wire guidance or mechanical (rail) guidance in the aisle
- BT Optipace system for top performance in all handling situations
- Programmable performance
- Extended service intervals

